

5-1/4" WATEROUS® PACER FIRE HYDRANT
BY AMERICAN FLOW CONTROL®



AMERICAN

FLOW CONTROL

THE RIGHT WAY

CONSTRUCTION

Fully complies with ANSI/AWWA C502 and is available UL Listed and FM Approved in applicable configurations.

DUCTILE IRON NOZZLE SECTION AND STAND PIPE

Is provided with an epoxy primer and polyurethane top coat for improved durability, color and gloss retention.

TRAVEL STOP NUT

Limits rod travel and helps eliminate rod buckling, Protects the interior coating by preventing valve bottom contact with base.

360° NOZZLE SECTION ROTATION

The Waterous stainless steel retaining ring system allows 360° rotation by loosening only four flange bolts and turning the nozzle section to the exact position desired.

TRAFFIC SECTION

Parts are designed to break at the ground line. Simple low-cost repair kit available.

STAINLESS STEEL BOLTING BELOW GRADE

Long-term corrosion resistance.

EPOXY-COATED LOWER COMPONENTS

Ductile iron base and lower and upper valve washers are fusion bond epoxy coated for corrosion resistance.

FLAT BOTTOM AND STRAPPING LUGS

All standard to make solid, straight installation faster and easier.

TWO-PIECE OPERATING NUT

Ductile iron upper section provides strength for wrenching. Lower portion is bronze for smooth operation and corrosion resistance.

MECHANICALLY ATTACHED NOZZLES

Exclusive design eliminates the use of hard to remove threaded barrel designs and the need to use nozzle retention pins or set screws that may become dislodged or lost.

CENTRIFUGALLY CAST DUCTILE IRON BARRELS

Stronger, smoother and more uniform than static cast barrels.

ALL-BRONZE DRAIN

No composition rubber, plastic or leather face to wear, peel or crack.

BRONZE-TO-BRONZE SEATING

O-ring protected bronze valve seat threads into a bronze insert in the hydrant bottom.

INTEGRAL CAP NUT AND LOWER WASHER

Protects rod threads from corrosion and makes servicing easy. Valve assembly is locked in place.

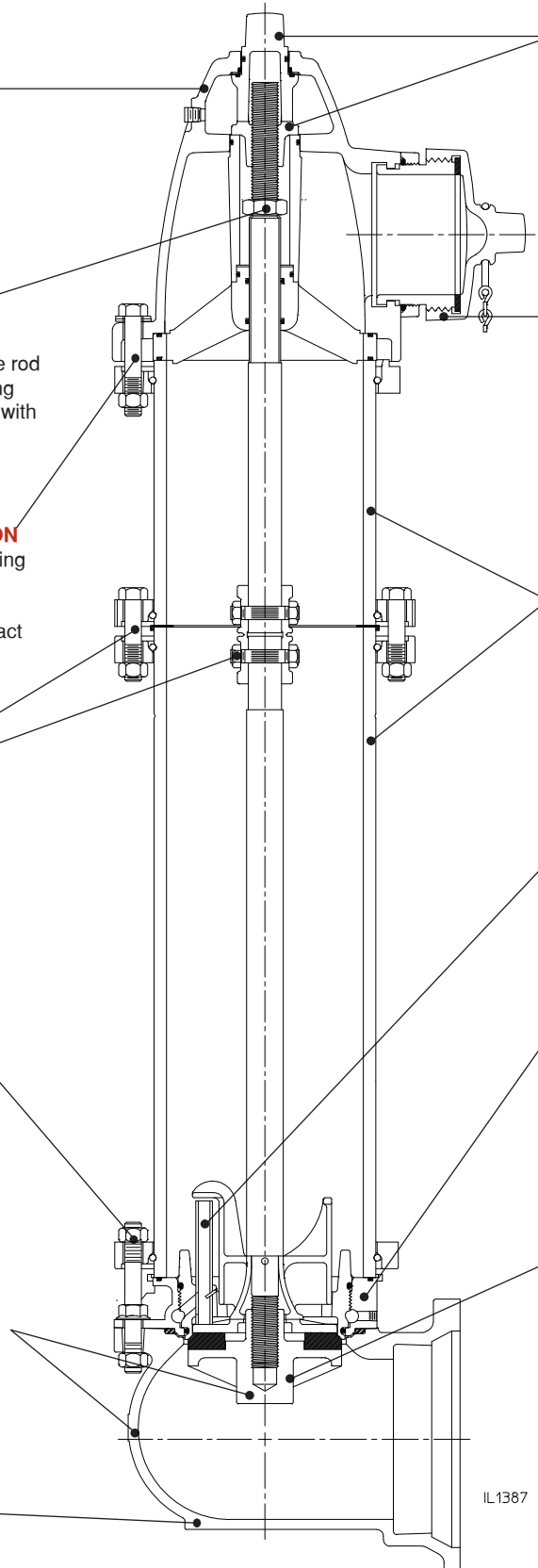

IL1387

SECTIONAL DRAWINGS/DIMENSIONS

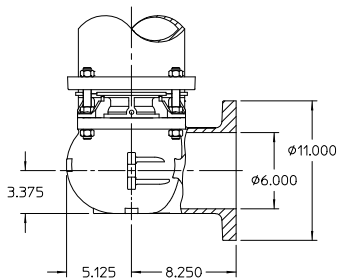
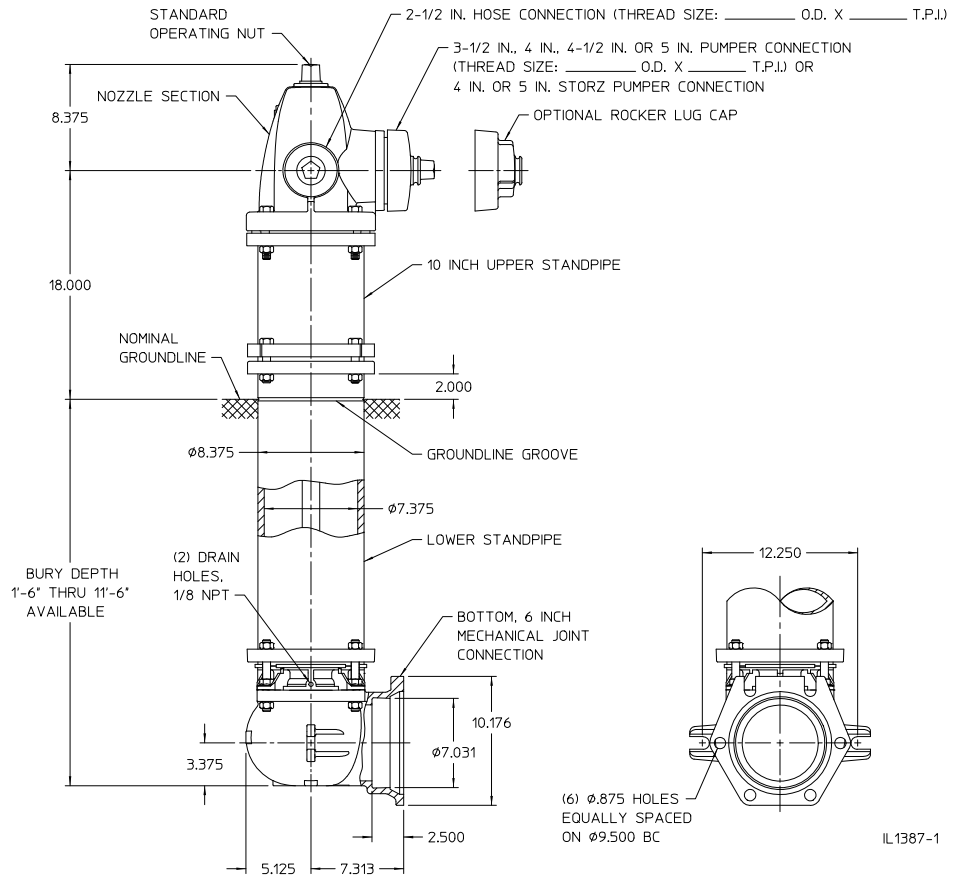

6 INCH CLASS 125 ANSI
FLANGED CONNECTION

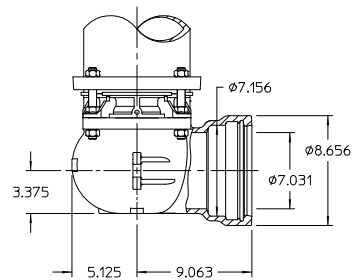

6 INCH TYTON®
JOINT CONNECTION
TYTON® is a registered trademark of
United States Pipe and Foundry Co., LLC.

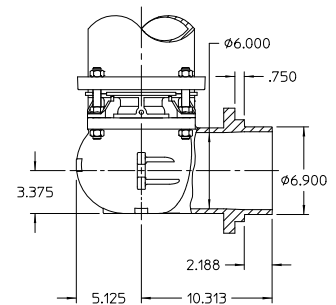

6 INCH PLAIN END W/INTEGRAL
MJ GLAND CONNECTION

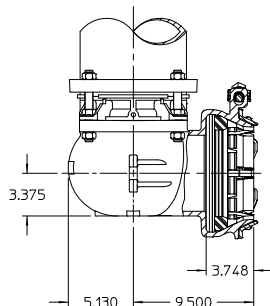

6 INCH ALPHA™ CONNECTION
ALPHA™ is a licensed trademark of
Romac Industries, Inc. (U.S. Patent 8,894,100)

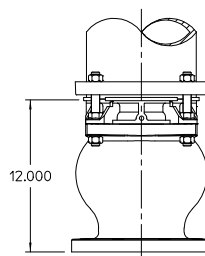

6 INCH FLANGED VERTICAL ENTRY CONNECTION

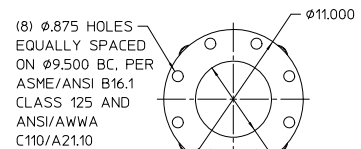

5-1/4" WATEROUS PACER FIRE HYDRANT

PARTS LIST

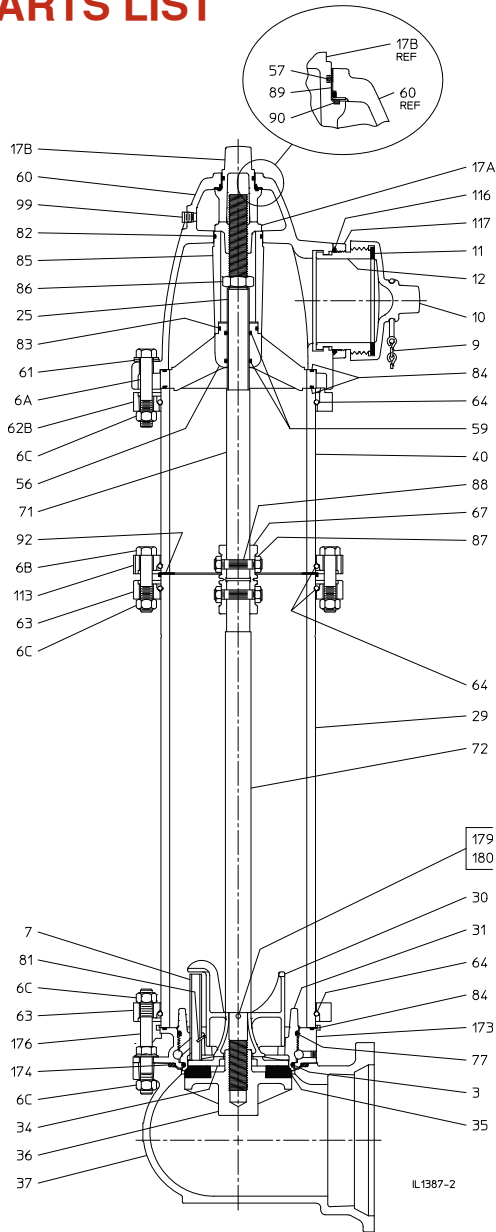

REF NO.	DESCRIPTION	MATERIAL
3	O-ring (Lower valve seat), 5-5/8 x 5-7/8	Rubber
6A	Hex hd bolt, 5/8-11 x 3-3/4 in.	Plated steel
6B	Hex hd bolt, 5/8-11 x 3 in.	Plated steel
6C	Hex nut, 5/8-11 (below grade)	Stainless steel
6C	Hex nut, 5/8-11 (above grade)	Plated steel
7	Drain plunger	Bronze
9A, 9B	Nozzle cap chain, single or double	Plated steel
10	Nozzle cap, hose or pumper	Ductile iron
11	Cap gasket, hose or pumper	Rubber
12	Nozzle, hose or pumper	Bronze
17A	Lower operating nut	Bronze
17B	Upper operating nut	Ductile iron
25	Rod bushing	Bronze
29	Lower standpipe	Centrifugally cast ductile iron pipe
30	Crossarm	Bronze
31	Valve seat	Brass
34	Upper valve washer	Ductile iron
35	Main valve rubber	Urethane
36	Lower valve washer	Ductile iron
37	Hydrant bottom	Ductile iron
40	Upper standpipe	Centrifugally cast ductile iron pipe
56	Support wheel	Ductile iron
57	O-ring (Operating nut), 1-1/2 x 1-3/4	Rubber
59	O-ring (Support wheel), 1-1/8 x 1-3/8	Rubber
60	Nozzle section	Ductile iron
61	Bury depth plate	Aluminum
61	Bury depth plate washer	Plated steel
62B	Upper standpipe flange	Ductile iron
63	Standpipe flange	Ductile iron
64	Flange lock ring	Stainless steel
67	Coupling sleeve (two halves)	Gray iron
71	Upper rod	Steel rod
72	Lower rod	Steel rod
77	O-ring (Upper valve seat), 5-7/8 x 6-1/8	Rubber
81	Groove pin, 3/32 x 7/16 in.	Copper
82	O-ring (Upper tube seal), 2-3/8 x 2-5/8	Rubber
83	O-ring (Lower tube seal), 1-7/8 x 2-1/8	Rubber
84	Support wheel/lower standpipe gasket	Rubber
85	Support tube	Ductile iron
86	Stop nut, 1"- 8	Plated steel
87	Coupling nut, 1/2-20	Brass
88	Coupling stud, 1/2-20 x 2-9/16 in.	Stainless steel
89	Nozzle section bushing	Bronze
90	Thrust ring	Polymer bearing
92	Upper standpipe gasket	Rubber
99	Pipe plug, 1/4 NPT	Brass
113	Breakable flange	Ductile iron
116	O-ring (pumper nozzle), 5-1/4 x 5-3/4	Rubber
117	Pumper nozzle retainer	Ductile iron
118	O-ring (hose nozzle), 3-1/4 x 3-5/8	Rubber
119	Hose nozzle retainer	Ductile iron
173	Valve seat insert	Brass
174	Valve seat insert gasket	Rubber
176	Stud, 5/8-11 x 5.650 in.	Stainless steel
179	Clevis pin, 1/4 x 1-11/16 in.	Stainless steel
180	Kick-out ring	Stainless steel

Notes:

1. 250 psig rated working pressure.
2. Meets or exceeds all requirements of ANSI/AWWA C502.
3. May be ordered in configurations that are UL Listed and FM Approved.
4. Nominal turns to open is 18.

AMERICAN Flow Control strongly recommends following routine maintenance on fire hydrants as outlined in AWWA Manual M-17 for Installation, Field Testing and Maintenance of Fire Hydrants. The ease of operation and the frequency of repair depends on the condition of the water system and the maintenance given. Dirt, gravel and other foreign material in the hydrant may prevent it from closing or draining properly, which may result in damage to the hydrant main valve. Under most operating conditions AMERICAN Flow Control recommends semiannual lubrication and inspection of fire hydrants.

FEATURES

The 5-1/4" Waterous® Pacer fire hydrant, by AMERICAN Flow Control® exhibits a sleek and stylish design that blends perfectly with today's modern architecture. The Pacer is rated for 250 psig and meets or exceeds all of the requirements of ANSI/AWWA C502. Ductile iron construction assures strength and durability.

The 5-1/4" Waterous Pacer fire hydrant provides real solutions to today's system demands. With many cities experiencing increased pressure to stretch their dollars, it is important to note that the Pacer hydrant can be maintained by just one person. The removal of four nuts and bolts allows access to all working parts.

5-1/4" Waterous Pacer standard features:

- All-bronze drain
- Travel stop nut located in top of hydrant
- Easy 360° rotation of nozzle section
- 250 psig working pressure rating
- Tested at 500 psig
- Two-part catalyzed epoxy primer and polyurethane coating system above grade

The 5-1/4" Waterous Pacer fire hydrant is Certified to NSF/ANSI/CAN 61 and NSF/ANSI/CAN 372, which exhibit compliance with the U.S Safe Drinking Water Act.

The Waterous Pacer hydrant has all the features you expect from a high-quality fire hydrant. The epoxy primer and polyurethane top coating system on external surfaces above grade provide a durable, high-gloss finish that will continue to look good for years without repainting. The all-bronze valve seat and bronze seat insert ensure that the Pacer hydrant remains easy to repair. The Waterous Pacer has been manufactured for many years while still maintaining parts interchangeability.

- Ductile iron nozzle section, upper and lower stand pipes and hydrant base
- Lubrication chamber
- Stainless steel bolting below grade
- Bronze-to-bronze seating
- Bronze cross arm
- Design employs long-term part interchangeability

BENEFITS

Easy Nozzle Section Rotation

The Waterous Pacer's stainless steel flange lock ring allows 360° rotation of nozzle section by merely loosening four bolts and turning nozzle section to the exact position required. This is done without damage to barrel gaskets.

Lubrication Chamber

O-rings help seal operating threads from water and debris.

All-Bronze Drain

No composition rubber, plastic or leather to wear, peel or crack.

Top Travel Stop Nut

Limits rod travel and helps eliminate rod buckling, Protects the interior coating by preventing valve bottom contact with base.

SPECIFICATIONS

Fire hydrants shall meet or exceed ANSI/AWWA C502, latest revision and Certified to NSF/ANSI/CAN 61 and NSF/ANSI/CAN 372. Rated working pressure shall be 250 psig, test pressure shall be 500 psig and hydrants shall include the following specific design criteria:

The nozzle section, upper and lower stand pipes and hydrant base shall be ductile iron.

External surfaces above grade shall be factory coated with an epoxy primer and a two-part polyurethane top coating.

The main valve closure shall be of the compression type, opening against the pressure and closing with the pressure. Nozzle section to be designed for easy 360° rotation by the loosening of no more than four bolts.

The valve opening diameter shall be 5-1/4". Hydrant must be designed so that removal of all working parts can be accomplished without excavating. The bronze seat shall be threaded into mating threads of bronze for easy field repair.

Bolting below grade shall be stainless steel.

The draining system of the hydrant shall be bronze and be positively activated by the main operating rod. Hydrant to be furnished with a sliding bronze drain valve. Sliding drain valves made of rubber, plastic or leather will not be allowed.

Hydrant must have an internal travel stop nut located in the top housing of the hydrant.

Hydrant operating threads to be factory lubricated. O-rings shall be furnished to help keep operating threads lubricated and protected from line fluid and from the weather.

Hydrant must have a traffic flange design allowing for quick and economical repair of damage resulting from a vehicle's impact. Hydrants shall be the 5-1/4" Waterous® Pacer by AMERICAN Flow Control®.



AMERICAN

FLOW CONTROL

THE RIGHT WAY

AMERICAN Flow Control

P.O. Box 2727
Birmingham, AL 35202-2727
Phone: 800-326-8051
Fax: 800-610-3569
Email: afcsales@american-usa.com

Waterous Company

125 Hardman Avenue South
South St. Paul, MN 55075-2421
Phone: 888-266-3686
Fax: 800-601-2809
Email: afcsales@american-usa.com

WWW.AMERICAN-USA.COM

Distributed By:



Pacer Product Information

Product literature may become outdated. AMERICAN is not responsible for out-of-date information, errors or omissions.
Please contact AMERICAN for the most current product information.